

ATX™ ECDX Series Customized Welded Steel Enclosures

Flameproof

ATEX/IECEX:
 Zone 1 and 2 - 21 and 22
 Ⓜ II 2 GD
 IP66 - IK10

Applications

- Designed for use in Zones 1, 2, 21 and 22 in the oil and gas industry; i.e. petroleum, chemical, refineries, and other industrial process facilities.
- Enclosures may be customized to house terminal blocks, and a large range of components; i.e. control units, breakers, starters, relays, meters, etc.

Features

- Enclosures are available in a wide range of sizes.
- Precision machined flameproof joint between body and cover.
- Hinged door.
- External fixing lugs.
- Internal mounting pan.
- Square and round windows available in a wide range of sizes.
- Machining and drilling must be done at our factory.
- Power dissipated calculation including cables must be completed according to each size of certified enclosure.

Standard Materials

- Gray painted mechanically welded steel enclosure
- Stainless steel hardware

Options

- Indirect cable entries available through Ex e connection enclosure.
- Factory assembled and wired.
- Switch rack assembly.
- Empty enclosure with Ex “U” component marking for recertification by notified body (CMS3-4-5-6-7-40-43-44U).

ATEX/IECEX Certifications and Compliances

- Certification Type CMS
 - Gas, Zones 1 and 2
 - Conforming to ATEX 94/9/CE: Ⓜ II 2 G
 - Type of Protection: Ex d IIB
 - Temperature Class: T6 to T4
 - Dust, Zones 21 and 22
 - Conforming to ATEX 94/9/CE: Ⓜ II 2 D
 - Type of Protection: Ex tD
 - Surface Temperature: T80 °C to T130 °C (T176 °F to T266 °F)

ECDX Series



Example of Customized Enclosure



- Ambient Temperature: -20 °C to +55 °C (-4 °F to +131 °F)
- CE Declaration of Conformity: 50236
- ATEX Certificate: LCIE 02 ATEX 6247X
- IECEx Certificate: IECEx LCI 080024X
- Internal Volume: > 2dm³ (122 in³) — 2 liters
- Index of Protection according EN/IEC 60529: IP66
- Impact Resistance (shock): IK10
- Certification Type CMS 3U-4U-5U-6U-7U-40U-43U
 - Gas, Zones 1 and 2
 - Conforming to ATEX 94/9/CE: Ⓜ II 2 G
 - Type of Protection: Ex d IIB
 - Dust, Zones 21 and 22
 - Conforming to ATEX 94/9/CE: Ⓜ II 2 D
 - Type of Protection: Ex tD
 - Ambient Temperature: -20 °C to +55 °C (-4 °F to +131 °F)
 - CE Declaration of Conformity: 5C235
 - ATEX Certificate: LCIE 07 ATEX 0008U
 - Internal Volume: > 2dm³ (122 in³) — 2 liters
 - Index of Protection according EN/IEC 60529: IP66
 - Impact Resistance (shock): IK10

EURASEC Certification

- Certification Type CMS
 - EURASEC N° TC RU C-FR.Г505.B.00911

Other Certification

- Certification Type CMS
 - INMETRO Certificate: BVC 11.0641-X ①

Catalog Numbering Guide – ECDX Customized Enclosures

ECDX
 |
 Series:
 ECDX - ATEX/IECEX Certified Enclosure

B
 |
 Classification:
 B - IIB

|
 Internal Dimensions mm (in):
 Length x Width x Depth
 (see ordering information on following page)

S
 |
 Options:
 S - 316L Stainless Steel
 U - Component Certification U
 # - Customized Enclosures
 (6 digit number will be assigned
 at time of order placement)

① INMETRO certification available on special request only. Contact your local sales representative for more information.

ATX™ ECDX Series Customized Welded Steel Enclosures

Flameproof

ATEX/IECEX:
 Zone 1 and 2 - 21 and 22
 II 2 GD
 IP66 - IK10

Type	Dimensions — L x W x D mm (in)	Weight kg (lb)	Volume dm ³ (in ³)	Catalog Number
Ex d IIB Enclosure in Welded Steel ①				
CMS3	300 (11.81) x 270 (10.63) x 180 (7.09)	92 (202.83)	234 (14279.6)	ECDXB302718
CMS4	415 (16.34) x 260 (10.24) x 285 (11.22)	152 (335.10)	234 (14279.6)	ECDXB412628
CMS5	415 (16.34) x 385 (15.16) x 285 (11.22)	180 (396.83)	369 (22517.8)	ECDXB413828
CMS6	635 (25.00) x 375 (14.76) x 345 (13.58)	336 (740.75)	647 (39482.4)	ECDXB633734
CMS7	635 (25.00) x 575 (22.64) x 345 (13.58)	384 (846.58)	647 (39482.4)	ECDXB635734
CMS47	700 (27.56) x 500 (19.69) x 295 (11.61)	268 (590.84)	698 (42594.6)	ECDXB705029
CMS43	700 (27.56) x 600 (23.62) x 295 (11.61)	298 (656.98)	698 (42594.6)	ECDXB706029
CMS46	700 (27.56) x 700 (27.56) x 295 (11.61)	318 (701.07)	698 (42594.6)	ECDXB707029
CMS44	800 (31.50) x 500 (19.69) x 295 (11.61)	298 (656.98)	698 (42594.6)	ECDXB805029
CMS40	800 (31.50) x 600 (23.62) x 295 (11.61)	318 (701.07)	698 (42594.6)	ECDXB806029
CMS42	800 (31.50) x 700 (27.56) x 295 (11.61)	308 (679.02)	698 (42594.6)	ECDXB807029
CMS45	900 (35.43) x 500 (19.69) x 295 (11.61)	348 (767.21)	698 (42594.6)	ECDXB905029
CMS41	900 (35.43) x 600 (23.62) x 295 (11.61)	348 (767.21)	698 (42594.6)	ECDXB906029
CMS57	1000 (39.37) x 550 (21.65) x 295 (11.61)	395 (870.83)	1144 (69811.2)	ECDXB105529
CMS52	1000 (39.37) x 630 (24.80) x 295 (11.61)	430 (947.99)	1144 (69811.2)	ECDXB106329
CMS55	1000 (39.37) x 700 (27.56) x 295 (11.61)	452 (996.49)	1144 (69811.2)	ECDXB107029
CMS53	1200 (47.24) x 550 (21.65) x 295 (11.61)	445 (981.06)	1144 (69811.2)	ECDXB125529
CMS50	1200 (47.24) x 630 (24.80) x 295 (11.61)	485 (1069.24)	1144 (69811.2)	ECDXB126329
CMS54	1200 (47.24) x 700 (27.56) x 295 (11.61)	515 (1135.38)	1144 (69811.2)	ECDXB127029
CMS56	1400 (55.12) x 550 (21.65) x 295 (11.61)	495 (1091.29)	1144 (69811.2)	ECDXB145529
CMS51	1400 (55.12) x 630 (24.80) x 295 (11.61)	540 (1190.50)	1144 (69811.2)	ECDXB146329
Ex d IIB Enclosure in 316L Stainless Steel ②				
CMS3	300 (11.81) x 270 (10.63) x 180 (7.09)	92 (202.83)	234 (14279.6)	ECDXB302718S
CMS4	415 (16.34) x 260 (10.24) x 285 (11.22)	152 (335.10)	234 (14279.6)	ECDXB412628S
CMS5	415 (16.34) x 385 (15.16) x 285 (11.22)	180 (396.83)	369 (22517.8)	ECDXB413828S
CMS6	635 (25.00) x 375 (14.76) x 345 (13.58)	336 (740.75)	647 (39482.4)	ECDXB633734S
CMS7	635 (25.00) x 575 (22.64) x 345 (13.58)	384 (846.58)	647 (39482.4)	ECDXB635734S
CMS47	700 (27.56) x 500 (19.69) x 295 (11.61)	268 (590.84)	698 (42594.6)	ECDXB705029S
CMS43	700 (27.56) x 600 (23.62) x 295 (11.61)	298 (656.98)	698 (42594.6)	ECDXB706029S
CMS46	700 (27.56) x 700 (27.56) x 295 (11.61)	318 (701.07)	698 (42594.6)	ECDXB707029S
CMS44	800 (31.50) x 500 (19.69) x 295 (11.61)	298 (656.98)	698 (42594.6)	ECDXB805029S
CMS40	800 (31.50) x 600 (23.62) x 295 (11.61)	318 (701.07)	698 (42594.6)	ECDXB806029S
CMS42	800 (31.50) x 700 (27.56) x 295 (11.61)	308 (679.02)	698 (42594.6)	ECDXB807029S
CMS45	900 (35.43) x 500 (19.69) x 295 (11.61)	348 (767.21)	698 (42594.6)	ECDXB905029S
CMS41	900 (35.43) x 600 (23.62) x 295 (11.61)	348 (767.21)	698 (42594.6)	ECDXB906029S
CMS57	1000 (39.37) x 550 (21.65) x 295 (11.61)	395 (870.83)	1144 (69811.2)	ECDXB105529S
CMS52	1000 (39.37) x 630 (24.80) x 295 (11.61)	430 (947.99)	1144 (69811.2)	ECDXB106329S
CMS55	1000 (39.37) x 700 (27.56) x 295 (11.61)	452 (996.49)	1144 (69811.2)	ECDXB107029S
CMS53	1200 (47.24) x 550 (21.65) x 295 (11.61)	445 (981.06)	1144 (69811.2)	ECDXB125529S
CMS50	1200 (47.24) x 630 (24.80) x 295 (11.61)	485 (1069.24)	1144 (69811.2)	ECDXB126329S
CMS54	1200 (47.24) x 700 (27.56) x 295 (11.61)	515 (1135.38)	1144 (69811.2)	ECDXB127029S
CMS56	1400 (55.12) x 550 (21.65) x 295 (11.61)	495 (1091.29)	1144 (69811.2)	ECDXB145529S
CMS51	1400 (55.12) x 630 (24.80) x 295 (11.61)	540 (1190.50)	1144 (69811.2)	ECDXB146329S



① For component certification and/or customized enclosure add digits as per examples: ECDXB302718# or ECDXB302718U#.
 ② For component certification and/or customized enclosure add digits as per example: ECDXB302718S# or ECDXB302718SU#.

ATX™ ECDX Series Customized Welded Steel Enclosures

Flameproof

ATEX/IECEX:
 Zone 1 and 2 - 21 and 22
 II 2 GD
 IP66 - IK10

Dimensions in Millimeters (Inches)

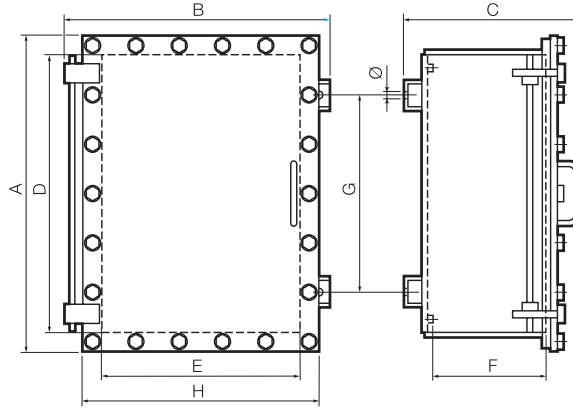

Type	External			Internal			Fixings Lug Thick			
	A	B	C	D	E	F	G	H	mm (in)	Ø
CMS3	388 (15.28)	440 (17.32)	318 (12.52)	300 (11.81)	270 (10.63)	180 (7.09)	200 (7.87)	370 (14.57)	7 (0.28)	16 (0.63)
CMS4	503 (19.80)	429 (16.89)	418 (16.46)	415 (16.34)	260 (10.24)	280 (11.02)	315 (12.40)	360 (14.17)	7 (0.28)	16 (0.63)
CMS5	503 (19.80)	554 (21.81)	418 (16.46)	415 (16.34)	385 (15.16)	280 (11.02)	315 (12.40)	485 (19.09)	7 (0.28)	16 (0.63)
CMS6	723 (28.46)	554 (21.81)	478 (18.82)	635 (25)	375 (14.76)	340 (13.39)	455 (17.91)	475 (18.70)	7 (0.28)	16 (0.63)
CMS7	723 (28.46)	745 (29.33)	478 (18.82)	635 (25)	575 (22.64)	340 (13.39)	470 (18.50)	675 (26.57)	7 (0.28)	16 (0.63)
CMS47	796 (31.34)	650 (25.59)	445 (17.52)	700 (27.56)	500 (19.69)	295 (11.61)	500 (19.69)	600 (23.62)	7 (0.28)	18 (0.71)
CMS43	796 (31.34)	750 (29.53)	445 (17.52)	700 (27.56)	600 (23.62)	295 (11.61)	500 (19.69)	700 (27.56)	7 (0.28)	18 (0.71)
CMS46	796 (31.34)	850 (33.46)	445 (17.52)	700 (27.56)	700 (27.56)	295 (11.61)	500 (19.69)	800 (31.50)	7 (0.28)	18 (0.71)
CMS44	896 (35.28)	650 (25.59)	445 (17.52)	800 (31.50)	500 (19.69)	295 (11.61)	600 (23.62)	600 (23.62)	7 (0.28)	18 (0.71)
CMS40	896 (35.28)	750 (29.53)	445 (17.52)	800 (31.50)	600 (23.62)	295 (11.61)	600 (23.62)	700 (27.56)	7 (0.28)	18 (0.71)
CMS42	896 (35.28)	850 (33.46)	445 (17.52)	800 (31.50)	700 (27.56)	295 (11.61)	600 (23.62)	800 (31.50)	7 (0.28)	18 (0.71)
CMS45	996 (39.21)	650 (25.59)	445 (17.52)	900 (35.43)	500 (19.69)	295 (11.61)	600 (23.62)	600 (23.62)	7 (0.28)	18 (0.71)
CMS41	996 (39.21)	750 (29.53)	445 (17.52)	900 (35.43)	600 (23.62)	295 (11.61)	600 (23.62)	700 (27.56)	7 (0.28)	18 (0.71)
CMS57	1125 (44.29)	730 (28.74)	452 (17.80)	1000 (39.37)	550 (21.65)	295 (11.61)	700 (27.56)	660 (25.98)	7 (0.28)	22 (0.87)
CMS52	1125 (44.29)	810 (31.89)	452 (17.80)	1000 (39.37)	630 (24.80)	295 (11.61)	700 (27.56)	740 (29.13)	7 (0.28)	22 (0.87)
CMS55	1125 (44.29)	880 (34.65)	452 (17.80)	1000 (39.37)	700 (27.56)	295 (11.61)	700 (27.56)	810 (31.89)	7 (0.28)	22 (0.87)
CMS53	1325 (52.17)	730 (28.74)	452 (17.80)	1200 (47.24)	550 (21.65)	295 (11.61)	900 (35.43)	660 (25.98)	7 (0.28)	22 (0.87)
CMS50	1325 (52.17)	810 (31.89)	452 (17.80)	1200 (47.24)	630 (24.80)	295 (11.61)	900 (35.43)	740 (29.13)	7 (0.28)	22 (0.87)
CMS54	1325 (52.17)	880 (34.65)	452 (17.80)	1200 (47.24)	700 (27.56)	295 (11.61)	900 (35.43)	810 (31.89)	7 (0.28)	22 (0.87)
CMS56	1525 (60.04)	730 (28.74)	452 (17.80)	1400 (55.12)	550 (21.65)	295 (11.61)	1100 (43.31)	660 (25.98)	7 (0.28)	22 (0.87)
CMS51	1525 (60.04)	810 (31.89)	452 (17.80)	1400 (55.12)	630 (24.80)	295 (11.61)	1100 (43.31)	740 (29.13)	7 (0.28)	22 (0.87)